

# SERPAC 132

Electronics Enclosures

NOTES:  
1. WHEN MACHINE OR I PLATES MODIFICATIONS ARE REQUIRED, USE THE CENTER OF THE BOX TO DIMENSION.

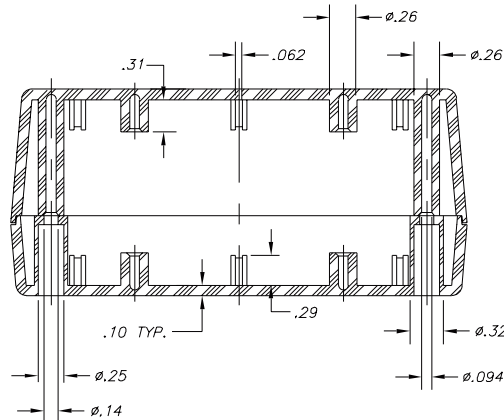
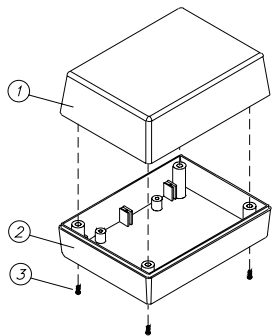
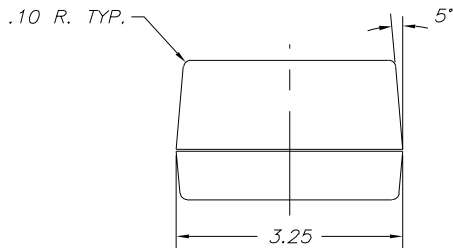
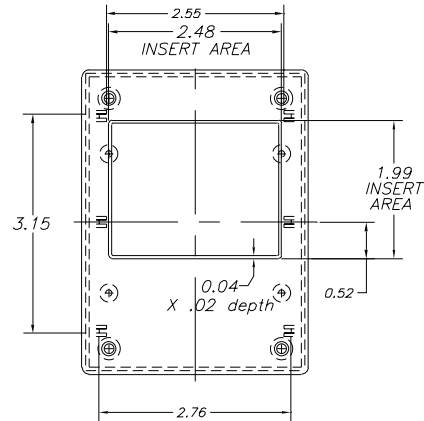
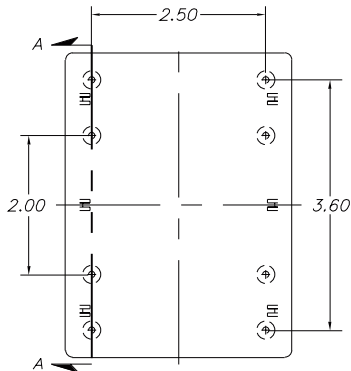
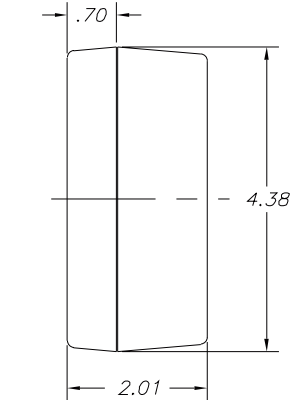

SECTION A-A

8-17-98.

ALL DIMENSIONS ± .010

ITEM	PART NO.	DESCRIPTION	ACCESSORIES	
1	32	PLASTIC TOP	PART NO.	DESCRIPTION
2	13	PLASTIC BOTTOM	50	FEET
3	6005	SCREWS (4)	330	PROTOTYPE GRID BOARD (HORIZ.)
			430	PROTOTYPE CLAD BOARD (HORIZ.)
			332	PROTOTYPE GRID BOARD (VERT.)
			432	PROTOTYPE CLAD BOARD (VERT.)
			PS-13	PERIMETER SEAL
			PC	POCKET CLIP

819 Commercial Ave. Covina, CA 91723

(626) 331-0517 Fax (626) 331-8584 <http://www.serpac.com>